

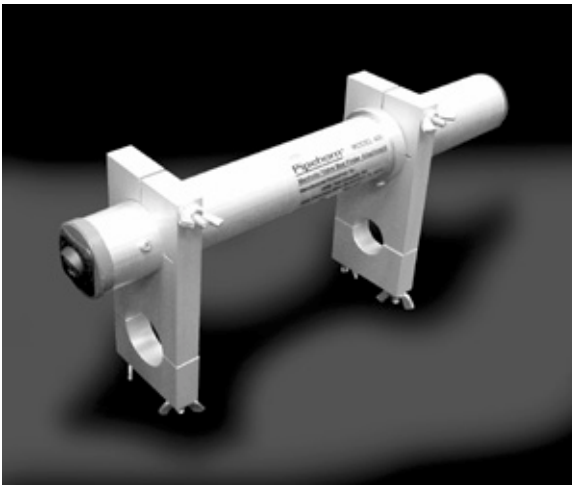

PA400

Valve & Manhole Cover Locator Attachment

Operator's Manual



Manufactured Exclusively By:
Utility Tool Company, Inc.
2900 Commerce Boulevard
Birmingham, Alabama 35210
205-956-3710

This device complies with Part 15 of the FCC Rules. Operation is subject to the following two conditions: (1) this device may not cause harmful interference and (2) this device must accept any interference received, including interference that may cause undesired operation.

NOTICE

This Operator's Manual is provided as an information guide only and is subject to change without notice.

This Manual contains certain information which is proprietary in nature and protected by U.S. and Foreign Patents, Copyrights, and Registered Trademarks. All rights are reserved. No part of this document may be photocopied, reproduced, transmitted, or converted into another language without the express written consent of Utility Tool Company, Inc.

© Utility Tool Company, Inc. 2005

Contents

Section	Page
1. Frequently Asked Questions	4
1.1 What is the PA400?	
1.2 What is it designed to do?	
1.3 Advantages	
2. Manual & Terminology	5
3. Set Up & Operation	6
3.1 Position & Test	
3.2 Locating a Cover	
4. Principles of Operation	9
4.1 Description of Equipment	
4.2 Theory of Operation	
5. Maintenance	13
5.1 Battery	
5.2 Warranty	
5.3 Repair Service	

1. Frequently Asked Questions

1.1 What is the PA400?

It is a transmitter that enables any Pipehorn receiver to detect metal objects, such as manhole and valve covers.

It is an accessory which is used with a Pipehorn locator, not a stand alone device. It mounts directly on the receiver and stores in the carrying case.

1.2 What is it designed to do?

Locate 95% or more of all buried and paved-over manhole and valve covers. Users said that 98% of lost covers were buried only 6 to 8 inches, so the instrument was designed to screen out small objects (coins, etc).

It is not designed to trace buried pipes and cables, though in some instances it may.

1.3 Advantages

The PA400 is especially effective in finding manhole and valve covers lost after street re-surfacing.

Physical Design - Mounts on any Pipehorn receiver, eliminating the need to carry two separate instruments. It stores easily in the Wooden Carrying Case.

Electronic Design - Screens out coins and cans. It is not a treasure finder. It finds non-ferrous and ferrous metals. No calibration is required.

Used in conjunction with a Pipehorn locator, the PA400 tells the operator:

- whether the object is directly over the target pipe or cable;
- the approximate size and shape (round or rectangular) of the object;
- the electrical center of the object.

2. Manual & Terminology

The information in this manual will help you locate manhole and valve covers successfully. It assumes the operator is familiar with the Pipehorn locator and describes how to operate the Pipehorn PA400 accessory for locating manhole and valve covers. The main areas covered are:

- Set Up & Operation
- Principles of Operation
- Maintenance

When the following terms are used in this manual, they have the meanings specified below:

Cover - any ferrous or non-ferrous metal object, including valve and manhole/vault lids and aluminum disks in plastic valve boxes

Conductor - pipe, cable, conduit, traceable fiber optic, tracer wire/tape, sewer snake, fish tape, or other lineal metallic structure

Signal - the output from the PA400 transmitter which is used to detect the concealed cover

Sensitivity - the amount of signal the receiver is set to detect; increasing the sensitivity allows the receiver to detect smaller or deeper covers

3. Set Up & Operation

3.1 Position & Test

a. Position the PA400 on top of the receiver as shown below with the bracket closest to the switch (rear bracket) on the black housing and the front bracket on the tee antenna shaft. Make sure that the bracket tops are parallel to each other and to the tee cross piece.

b. Position the front bracket and the tube so that the screws near the switch are against the rear bracket and the ring is against the front bracket.



c. Adjust the receiver sensitivity control to maximum (fully clockwise). Switch on the PA400 and, while squeezing the receiver switch, slowly rotate the tube through a complete 360°. If a tone is heard throughout the rotation, the units are operating satisfactorily. If not, replace the battery in the PA400, the receiver, or both.

d. Rotate the tube and increase the receiver sensitivity to achieve the sharpest null possible. for further explanation, see *4.1 Description of Equipment*.

3.2 Locating a Cover

a. Once the PA400 is positioned and the line under the cover located, switch off the main transmitter. Then switch on the PA400, squeeze the push button switch on the receiver, and adjust the sensitivity control for a shrill (high pitched) sound.

b. Holding the receiver vertically and close to the ground as shown below, scan the area of interest listening for the tone to go deep or beeping, which indicates the presence of a metal object.



c. To pinpoint the center of the object, adjust the sensitivity to get a sharp null at the center (see picture below).



d. To determine the size and shape of the object, adjust the sensitivity so that you can actually trace the edges of the cover, just as you would a line (see picture below).



4. Principles of Operation

4.1 Description of Equipment

The PA400 is a highly directional transmitter which mounts on any Pipehorn receiver. The only control is an on-off switch indicated in the picture below.

Position the PA400 on the receiver. For best results, it should be mounted on the top side of the receiver as shown. If it is operated on the underside of the receiver (the storage position), you may get interference from change, pocket knives, or steel toe boots.

Position the brackets and the tube. The rear bracket should be on the black receiver housing with the screws in the side of the tube up against it. The front bracket should be on the plastic shaft positioned so that the ring on the tube is up against it.



To store the receiver with the PA400 attached, loosen the brackets on the housing and the shaft and swing the PA400 underneath the receiver. In this position, it will store easily in the case as shown below.



For maximum depth penetration and detecting smaller objects, mechanically align the PA400. Loosen the upper side wing nuts on each bracket and rotate the tube until the slot in the front of the tube lines up with the slot in the front bracket.

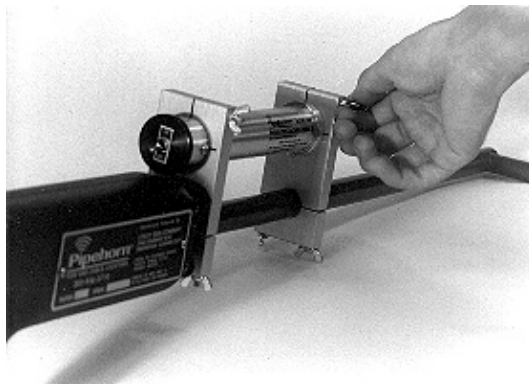

With the PA400 switch on, squeeze the receiver switch for the Pipehorn sound. Rotate the tube 90° to the right and back 90° to the left, looking for the null (no sound).

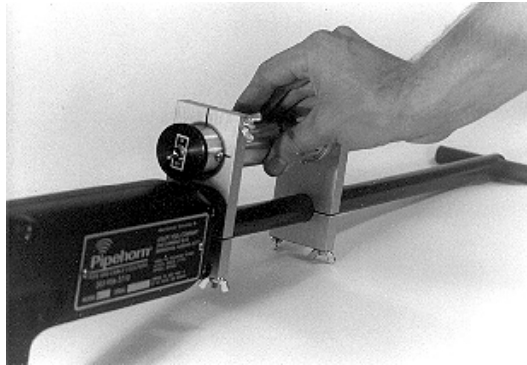

When you get to the null, increase the sensitivity until you hear a sound and continue rotating the tube in the same direction until you reach the null again. If you do not get a null, then the sensitivity is too high or the tube was not rotated far enough.

Repeat this procedure of increasing the sensitivity and rotating the tube until the slightest rotation in either direction results in moving out of the null (no sound) and into the Pipehorn sound.

When the tee antenna is brought near a metal object, the balance is disturbed and a net signal is produced resulting in the Pipehorn sound.

4.2 Theory of Operation

The PA400 is actually a small, highly directional transmitter which, when properly mounted and aligned, produces a balanced signal on the receiver tee antenna.

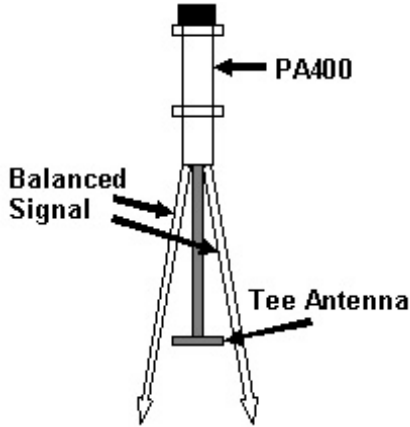

When placed over a metal object, the balance is disturbed and a net signal is produced resulting in the Pipehorn sound.

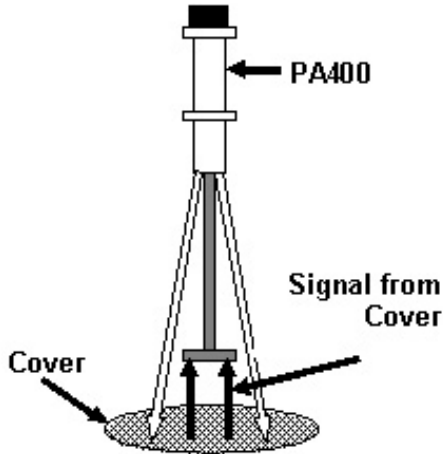

5. Maintenance

The PA400 Manhole/Valve Cover Locator Attachment has been permanently set to the proper frequency to give maximum performance with your Pipehorn. No adjustment or recalibration is necessary for the life of the equipment. Maintenance is limited to replacement of the battery.

5.1 Battery

The unit is equipped with a 9-volt Eveready 216/522 or equivalent, the same type of battery used in the receiver.

To change the battery, carefully remove the two screws in the side of the tube that hold the black switch/battery holder in position. Then pull the switch holder from the end of the tube and loosen the long screws which hold the battery and terminal in position. Replace the battery being sure not to pinch any wires.

NOTE: Remove battery when not in use.



5.2 Warranty

THERE ARE NO WARRANTIES, EXPRESSED OR IMPLIED, INCLUDING ANY WARRANTY OF MERCHANTABILITY, BEYOND THOSE STATE BELOW.

Utility Tool Company, Inc. warrants the PA400 to be free from defects in workmanship or material under normal and proper use and service for three years from the date of purchase by the original user. Batteries are not included in this Warranty. Unauthorized repair, alteration, or improper maintenance will nullify this Warranty. Alteration or removal of the serial number will also void the Warranty. Utility Tool Company will not be obligated under this Warranty if the equipment has been misused, misapplied, or accidentally damaged.

If a PA400 is found defective under this Warranty, Utility Tool Company will, at its option, repair or replace the unit free of charge at the Utility Tool Company factory. The unit should be returned to the factory prepaid with customary shipping precautions. The manufacturer's obligations under this Warranty are limited to the repair or replacement of defective parts which are not the result of alteration, misuse, abuse or accidental damage, or at the option of Utility Tool Company, the refund of the purchase price. Utility Tool Company assumes no other liabilities, contingent or consequential, to any defective equipment.

5.3 Repair Service

Make a copy of the back of this manual and fill in the information requested. Enclosing this form with the unit to be repaired will expedite your repair and provide our technicians with the information they need to do the best job possible.

For fast service (usually less than 48 hours), return the PA400 along with the Pipehorn locator and the form prepaid to:

Utility Tool Company, Inc.
Attn: Repair Dept.
2900 Commerce Blvd.
Birmingham, AL 35210
USA

Phone 205-956-3710

If you have questions or suggestions regarding our equipment or a particular application, contact our applications support group at the number listed above between 8:00 AM and 4:30 PM Central Time. Thank you for purchasing Pipehorn equipment. We value your business and want to keep it. Fill in the following for your records:

Pipehorn Model 400

Serial Number _____

Date of Purchase _____

Repair Request

Please fill out this request and return it with your Pipehorn to the address on the inside of this manual.

Company Name _____

Contact Person _____

(Area Code) Phone # _____

Please check the problem(s) that you have experienced:

Little or No Distance Damaged
 Can't Pinpoint Other: _____
 Cuts On & Off
 Low Volume or _____
 No Sound

Estimate Required? PO # Required:

PO # _____

Return Equipment To: _____

Send Invoice To (If Different): _____

Model # _____ Serial #(s) _____

Unless your organization currently has an account with us, we will return your Pipehorn C.O.D. to avoid any delays in getting your unit back to you quickly.